

## TECHNICAL DATA SHEET FOR Gas Griddle Toaster 600mm

CT6



CT6

- 600mm wide
- Stainless steel finish
- 2 x 21MJ burners
- Variable heat dual gas controls
- Flame failure protection with continuous pilot burner and piezo ignition
- 12mm thick griddle plate
- 5-position toasting rack
- Full width grease trough and removable collection tray
- Open cabinet base for extra storage
- Adjustable front feet and rear rollers

---

### Overall Construction

12mm machined surface mild steel griddle plate  
Stainless steel sides, splashguard and control panel  
Dual burners with individual pilot and flame failure  
Aluminised steel crumb tray and cabinet interior  
Chrome plated toasting rack and rack supports  
Two stainless steel grease trays  
50mm dia. stainless steel adjustable legs to front and two rollers at rear

### Controls

Large easy use control knobs  
Dual controls with variable high to low burner setting  
Flame failure pilot burners  
Piezo ignition to pilot burners

### Cleaning and Servicing

Removable grill rack system, rack supports and crumb tray  
Removable grease trays  
Easy clean stainless steel exterior  
Access to all parts from front of unit

## TECHNICAL DATA SHEET FOR Gas Griddle Toaster 600mm CT6

### Burners

2 x 21MJ/hr, 5.5kW tubular burners  
with grill radiants

### Gas power

42MJ/hr, 11kW

### Cooking surface

590mm x 520mm, 3068cm<sup>2</sup>

### Toaster Dimensions

Rack size 430mm x 470mm

Rack positions 4

### Gas connection

R<sup>1</sup>/<sub>2</sub> (BSP) male

130mm from RH side, 32mm from  
rear, and 655mm from floor

*All units supplied with Natural and  
LP gas regulator*

### Dimensions

Width 600mm

Depth 800mm

Height 915mm

Incl. splashback 1085mm

### Packing data

0.70m<sup>3</sup>

Width 640mm

Depth 865mm

Height 1255mm

93kg nett weight

143kg packed weight

### Gas types

Available in Natural gas and LP gas,  
please specify when ordering

*Other gas types on request*

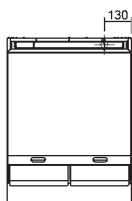
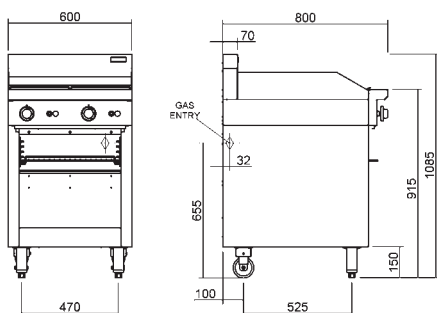

CT6

**MOFFAT®**

[www.moffat.com.au](http://www.moffat.com.au)

Australia  
Moffat Pty Limited

Victoria/Tasmania  
740 Springvale Road  
Mulgrave, Victoria 3170  
Ph 03-9518 3888  
Fax 03-9518 3833  
[vsales@moffat.com.au](mailto:vsales@moffat.com.au)  
[www.moffat.com.au](http://www.moffat.com.au)

New South Wales  
Ph 02-8833 4111  
[nswsales@moffat.com.au](mailto:nswsales@moffat.com.au)

South Australia  
Ph 03-9518 3888  
[vsales@moffat.com.au](mailto:vsales@moffat.com.au)

Queensland  
Ph 07-3630 8600  
[qldsales@moffat.com.au](mailto:qldsales@moffat.com.au)

Western Australia  
Ph 08-9202 6820  
[bgarcia@moffat.com.au](mailto:bgarcia@moffat.com.au)

New Zealand  
Moffat Limited

Christchurch  
16 Osborne Street  
Christchurch 8011  
Ph +64 3-389 1007  
Fax +64 3-389 1276

Auckland  
Ph +64 9-574 3150

[export@moffat.co.nz](mailto:export@moffat.co.nz)  
[www.moffat.co.nz](http://www.moffat.co.nz)



ISO9001  
Quality  
Management  
Standard

Designed and manufactured by

**MOFFAT®**

ISO9001  
All Cobra products are designed and  
manufactured by Moffat using the  
internationally recognised ISO9001  
quality management system, covering  
design, manufacture and final  
inspection, ensuring consistent high  
quality at all times.

Australian  
Gas Association  
Approved

In line with policy to continually develop  
and improve its products, Moffat Limited  
reserves the right to change  
specifications and design without notice.